

ANSI Abmessungen
Einfachdichtung
Entlastet
Massive Gleitringe
Drehrichtungsunabhängig
Stationär befedert
Spühlanschluß Standard

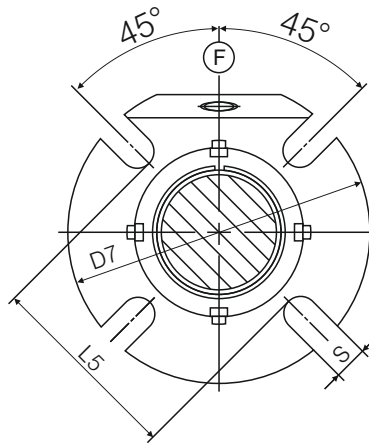

F-Spülanschluß

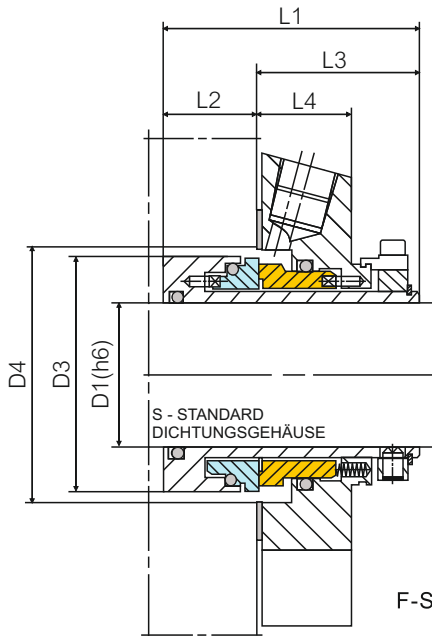
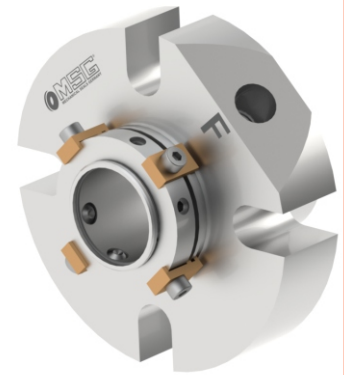
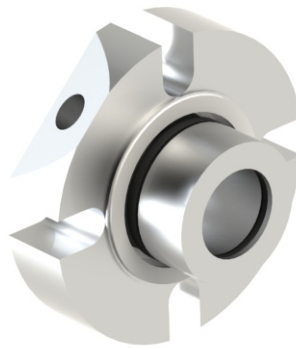
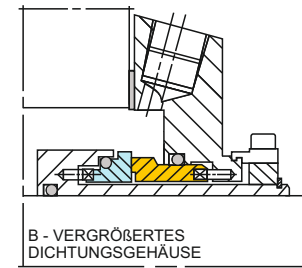

Werkstoffe:

Rotierend: Q, U

Stationär: A, B, Q, U

Nebendichtungen: P, E, V, K, M

S - STANDARD DICHTUNGSGEHÄUSE

D1	D3	D4 min	D4 max	L1	L2	L3	L4	L5	D7	S	Anschluss
1.000	1.693	1.732	2.205	2.937	1.028	1.909	1.000	2.756	3.937	0.433	1/4 NPT
1.125	1.713	1.752	2.205	2.937	1.028	1.909	1.000	2.440	4.134	0.437	1/4 NPT
1.250	1.969	2.008	2.402	3.130	1.028	2.102	1.000	2.638	4.252	0.433	1/4 NPT
1.375	1.961	2.000	2.402	2.947	1.028	1.919	1.000	2.760	4.213	0.437	1/4 NPT
1.500	2.200	2.244	2.717	3.130	1.028	2.102	1.000	2.950	4.488	0.551	3/8 NPT
1.625	2.340	2.421	2.795	3.130	1.028	2.102	1.000	3.030	4.921	0.551	3/8 NPT
1.750	2.461	2.500	2.953	3.012	1.028	1.984	1.000	3.228	5.118	0.559	3/8 NPT
1.875	2.583	2.661	3.070	3.071	1.028	2.043	1.000	3.190	5.118	0.551	3/8 NPT
2.000	2.677	2.756	3.189	3.130	1.028	2.102	1.000	3.430	5.472	0.630	3/8 NPT
2.125	2.834	2.913	3.583	3.012	1.028	1.984	1.000	3.820	5.512	0.650	3/8 NPT
2.250	2.960	3.039	3.583	3.130	1.028	2.102	1.000	3.858	5.866	0.650	3/8 NPT
2.375	3.070	3.125	3.590	3.130	1.028	2.102	1.000	4.020	6.181	0.709	3/8 NPT
2.500	3.212	3.291	3.937	3.130	1.028	2.102	1.122	4.528	6.693	0.709	3/8 NPT
2.625	3.338	3.417	4.016	3.130	1.028	2.102	1.250	4.528	6.378	0.603	3/8 NPT
2.750	3.660	3.740	4.370	3.130	1.028	2.102	1.260	4.646	7.441	0.709	3/8 NPT
3.000	3.937	4.016	4.724	3.858	1.343	2.516	1.260	5.000	7.835	0.709	3/8 NPT
3.250	4.189	4.268	4.921	3.858	1.343	2.516	1.260	5.315	7.830	0.709	3/8 NPT
3.750	4.689	4.750	5.433	3.858	1.343	2.516	1.000	5.827	8.189	0.866	3/8 NPT

B - VERGRÖßERTES DICHTUNGSGEHÄUSE

D1	D3	D4 min	D4 max	L1	L2	L3	L4	L5	D7	S	Anschluss
1.000	1.693	1.732	2.402	2.638	0.969	1.669	1.000	2.756	4.252	0.437	1/4 NPT
1.125	1.713	1.752	2.795	2.638	0.969	1.669	1.000	3.311	4.500	0.437	1/4 NPT
1.250	1.969	2.000	3.040	2.638	0.969	1.669	1.000	3.425	4.921	0.437	1/4 NPT
1.375	1.960	2.000	3.189	2.638	0.969	1.669	1.000	3.543	5.118	0.437	1/4 NPT
1.500	2.200	2.244	3.494	2.638	0.969	1.669	1.000	3.858	5.512	0.551	1/4 NPT
1.625	2.340	2.421	3.790	2.638	0.969	1.669	1.000	3.940	6.181	0.551	1/4 NPT
1.750	2.461	2.500	4.055	2.638	0.969	1.669	1.000	4.567	6.496	0.559	3/8 NPT
1.875	2.583	2.661	3.937	2.638	0.969	1.669	1.000	4.409	5.984	0.551	3/8 NPT
2.000	2.677	2.756	4.567	2.638	0.709	1.929	1.260	4.882	6.260	0.551	3/8 NPT
2.125	2.834	2.913	4.528	2.638	0.969	1.669	1.000	5.276	6.890	0.709	3/8 NPT
2.250	2.960	3.093	4.409	2.638	0.693	1.945	1.276	4.685	6.417	0.709	3/8 NPT
2.500	3.212	3.299	5.276	2.638	0.719	1.919	1.250	5.512	7.795	0.709	3/8 NPT
2.625	3.338	3.170	5.118	2.638	0.719	1.919	1.250	5.354	6.890	0.709	3/8 NPT
2.750	3.660	3.740	5.236	3.307	0.693	1.945	1.276	5.512	7.480	0.630	3/8 NPT
3.000	3.937	4.016	5.512	3.307	1.031	2.276	1.276	5.906	8.228	0.650	3/8 NPT
3.250	4.189	4.268	5.945	3.307	1.047	2.260	1.260	6.120	8.661	0.709	3/8 NPT

Cartridge Gleitringdichtungen