





Plunger valve 2/2-way direct-acting

- Direct-acting and compact valve up to diameter of DN 6.0
- Vibration-proof, bolted coil system
- Explosion proof versions
- Energy-saving version with Kick and Drop available



Product variants described in the data sheet may differ from the product presentation and description.

Can be combined with

	Type 1087 Timer, form A according to DIN EN 175301 - 803	▶
	Type 2518 Cable plug, form A according to DIN EN 175301 - 803	▶
	Type 2509 Cable plug, form A according to DIN EN 175301 - 803	▶

Type description

Valve 6013 is a direct-acting plunger valve. The stopper and plunger guide tube are welded together to enhance pressure resistance and leak-tightness. Various seal material combinations are available depending on the application. A Bürkert-specific flange design (SFB) enables space-saving arrangement of valves on a manifold. Kick and Drop coils are available for the reduction of electrical power consumption during operation.

Table of contents

1. General technical data	3
2. Product versions	4
2.1. Analytical version	4
Solenoid valves for higher requirements	4
3. Circuit functions	4
4. Approvals	4
5. Materials	5
5.1. Chemical Resistance Chart – Bürkert resistApp	5
5.2. Material specifications	5
Standard version	5
6. Dimensions	6
6.1. Standard version	6
6.2. Single manifold	7
6.3. Multiple manifold	7
Manifolds for block mounting	8
7. Performance specifications	8
7.1. Power consumption	8
Circuit function A	8
Circuit function B	8
8. Product installation	9
8.1. Installation notes	9
Control for impulse version with polarity reversal control	9
9. Ordering information	9
9.1. Bürkert eShop – Easy ordering and quick delivery	9
9.2. Bürkert product filter	9
9.3. Ordering chart	10
UL Recognized	10
UL Listed	11
UL Recognized Normally Open	12
UL Recognized low temperature version (-40 °F)	12
9.4. Ordering chart coil to be UL Listed for hazardous locations, Class I, Division 2	13
Cable versions	13
9.5. Ordering chart coil to be cFMus for hazardous locations, Class I, Division 1	14
Conduit versions	14
9.6. Ordering chart accessories	15
Single manifold	15
Multiple manifold	15
Cable plug Type 2509, form A according to DIN EN 175301 - 803	15
Cable plug Type 2518, form A according to DIN EN 175301 - 803	16

1. General technical data

Product properties	
Dimensions	Detailed information can be found in chapter "6. Dimensions" on page 6.
Material	
Seal	FKM, PTFE/Graphite (EPDM on request)
Body	Brass, stainless steel 1.4305 / 303
Orifice	DN 2.0...DN 6.0
Circuit function	A and B. Detailed information can be found in chapter "3. Circuit functions" on page 4.
Thermal insulation class of solenoid	Polyamide class B Epoxy class H
Performance data	
Duty cycle/single valve with block assembly on manifold	100 % continuous rating Intermittent operation 60 % (30 min) or with 5 W coil (on request)
Electrical data	
Operating voltage	
Standard version	12 V DC, 24 V DC, 24 V/50 Hz, 24 V/60 Hz, 120 V/50 Hz, 230 V/50 Hz, 240 V/60 Hz
Voltage tolerance	± 10 %
Medium data	
Operating medium	
Standard version	Technical vacuum, neutral gases and liquids (e.g. compressed air, water, hydraulic oil)
Analytical version	Neutral medium, which does not attack the body and seal materials (see "5.1. Chemical Resistance Chart – Bürkert resistApp" on page 5)
Medium temperature	
With FKM	14 °F...+212 °F (PA coil), 14 °F...+248 °F (Epoxy coil), -40 °F on request
With PTFE/Graphite	-40 °F...+356 °F (see "5.1. Chemical Resistance Chart – Bürkert resistApp" on page 5)
With FKM, circuit function B	14 °F...212 °F (AC),...14 °F...248 °F (DC)
Viscosity	Max. 21 cSt (21 mm ² /s)
Process/Port connection & communication	
Electrical connection	Tag connector acc. to DIN EN 175301 -803 form A for cable plug Type 2518 ▶ and Type 2509 ▶ (see "9.6. Ordering chart accessories" on page 15)
Port connection	
Standard version	G 1/8, G 1/4, G 3/8, NPT 1/8, NPT 1/4, NPT 3/8, manifold (SFB)
Analytical version	G 1/8, G 1/4, NPT 1/8, NPT 1/4
Approvals and certificates	
Degree of protection	IP65 with cable plug, IP67 with cable plug Type 2518 ▶ UL hazloc 2 with cable plug Type 2509 ▶ NEMA 4X with cable plug Type 2509 ▶ with stainless steel versions
Environment and installation	
Installation position	As required, preferably with actuator upright
Installation instructions	No oils, fats or silicone to be used during installation
Ambient temperature	Max. + 131 °F (higher temperatures on request)

2. Product versions

2.1. Analytical version

Solenoid valves for higher requirements

This version is particularly suitable for switching from extremely pure gaseous medium. All medium-affected parts are submitted to additional purification processes, so that the medium is not contaminated under any circumstances.

The tightness test takes place at the helium leak detector from a min. of 10^{-4} mbar l/sec.

Product properties

Material

Seal	Silicon, oil and fat free version Tightness $< 10^{-4}$ mbar l/s
Body	Brass, stainless steel 1.4305 / 303

Medium data

Operating medium	Neutral medium, which does not attack the body and seal materials (see "5.1. Chemical Resistance Chart – Bürkert resistApp" on page 5)
------------------	--

Process/Port connection & communication

Electrical connection	Tag connector acc. to DIN EN 175301-803 form A for cable plug Type 2518 ▶ and Type 2509 ▶ (see "9.6. Ordering chart accessories" on page 15)
Port connection	G 1/8, G 1/4, NPT 1/8, NPT 1/4



Environment and installation

Installation instructions	No oils, fats or silicone to be used during installation
---------------------------	--

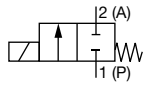
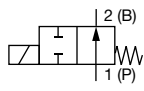
3. Circuit functions

Symbol	Description
	Circuit function A (CF A) 2/2-way solenoid valve Direct-acting Normally closed
	Circuit function B (CF B) 2/2-way solenoid valve Direct-acting Normally open

4. Approvals

Approvals	Description
	UL Listed for the USA UL Listed UL hazloc Div. 2 approval for coils with fixed cable outlet
	UL Recognized for the USA UR UL Recognized (coil material insulation class H) UL Recognized cURus (coil)
	cFMus approved (coil)

5. Materials

5.1. Chemical Resistance Chart – Bürkert resistApp

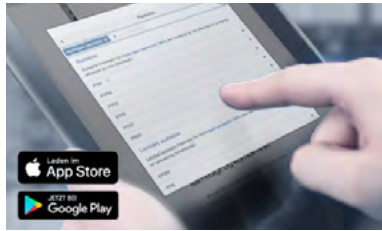

Bürkert resistApp – Chemical Resistance Chart

You want to ensure the reliability and durability of the materials in your individual application case? Verify your combination of media and materials on our website or in our resistApp.

[Start Chemical Resistance Check](#)

5.2. Material specifications

Standard version

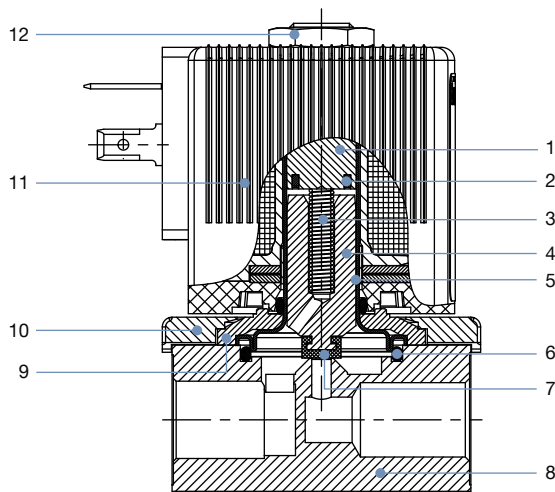

No.	Element	Material
1	Stopper	Stainless steel 1.4105 / 430F
2	Shading ring	Cu (brass version) Ag (stainless steel version)
3	Spring	Stainless steel 1.4310 / 301
4	Magnetic core	Stainless steel 1.4105 / 430F
5	Armature guide tube	Stainless steel 1.4303 / 305 / 308
6	Seal	FKM Graphite (high temp. version)
7	Armature seal	FKM PTFE (high temp. version)
8	Valve body	Brass Stainless steel 1.4305 / 303
9	Sub-base	Steel, surface finish thick-film passivated (brass version) Stainless steel 1.4301 / 304 (stainless steel version)
10	Cover	Polyamide
11	Coil	PA (polyamide) Epoxy (high temp. version)
12	Locknut	Steel, surface finish thick-film passivated (brass version) Stainless steel 1.4305 / 303 PTFE coated (stainless steel version)

6. Dimensions

6.1. Standard version

Note:

Dimensions in mm [inch]

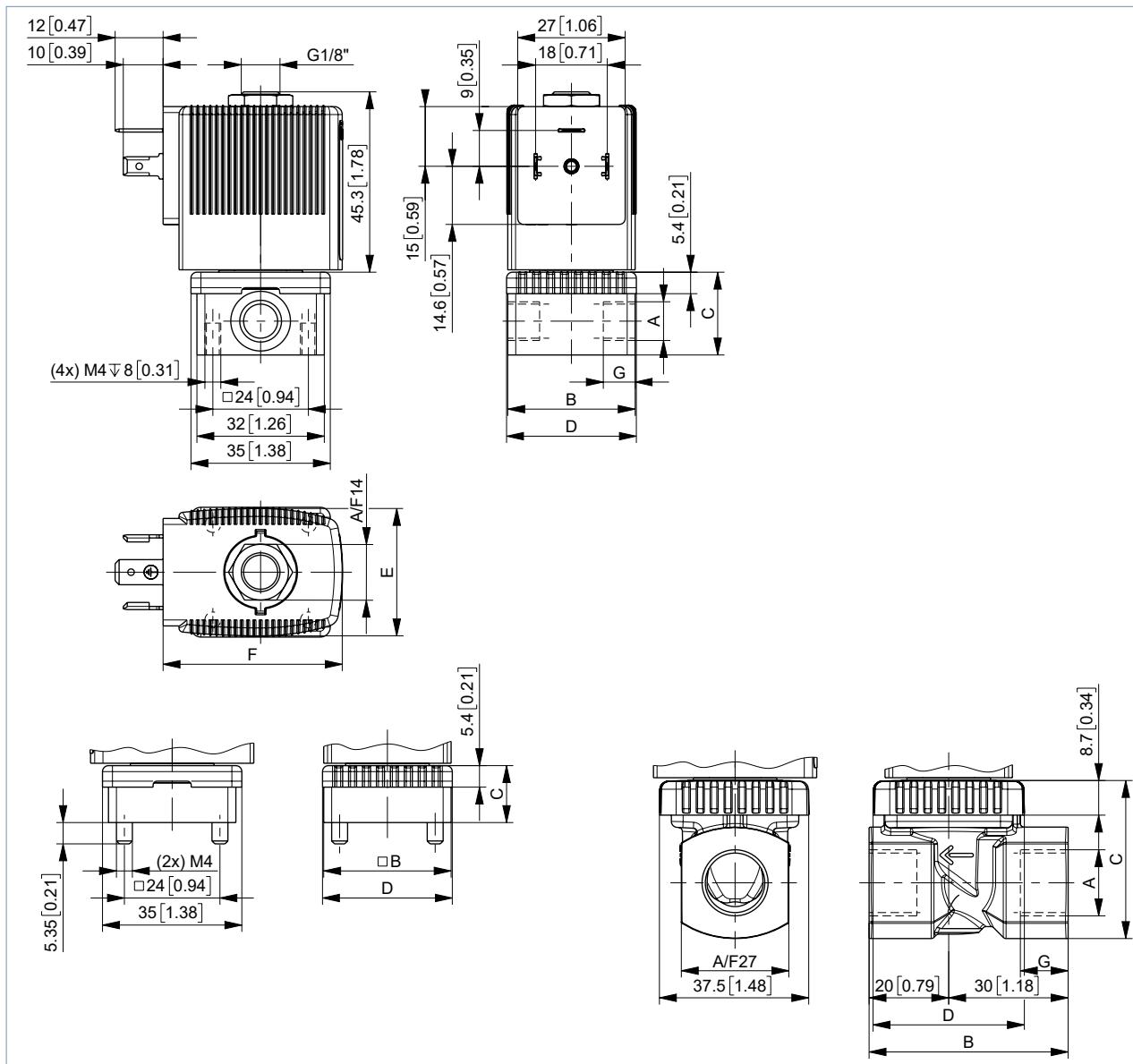

Port connection	A	B	C		D		G		
	[inch]	[mm]	[inch]	[mm]	[inch]	[mm]	[inch]	[mm]	[inch]
Threaded version	G/NPT 1/8	32	1.26	20.8	0.82	32.6	1.28	8	0.31
	G/NPT 1/4	46	1.81	26.8	1.06	49	1.93	12	0.47
	G/NPT 3/8	50	1.97	39.8	1.57	38	1.5	12	0.47
Flange version	-	32	1.25	14.3	0.56	32.6	1.28	-	-

Coil size	E		F	
	[mm]	[inch]	[mm]	[inch]
5	32	1.26	20.8	0.82
6	46	1.81	26.8	1.06

DTS 1000572169 EN Version: D Status: RL (released | freigegeben | valide) printed: 28.07.2023

6.2. Single manifold

Note:

- Dimensions in mm [inch]
- For detailed information on the installation of manifolds, see “Manifolds for block mounting” on page 8.

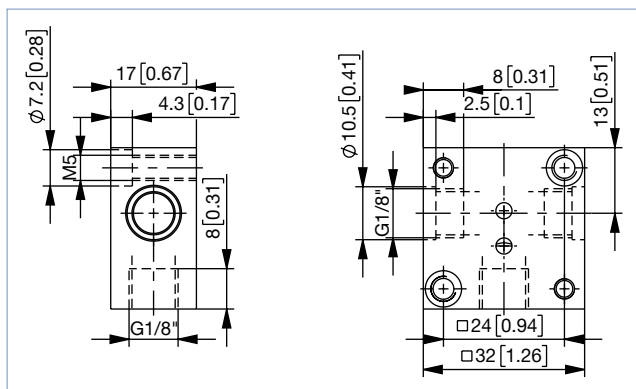

6.3. Multiple manifold

Note:

- Dimensions in mm [inch]
- Manifold only possible with coil size 5 (32 mm [1.26 inch])
- Brass or stainless steel manifold on request

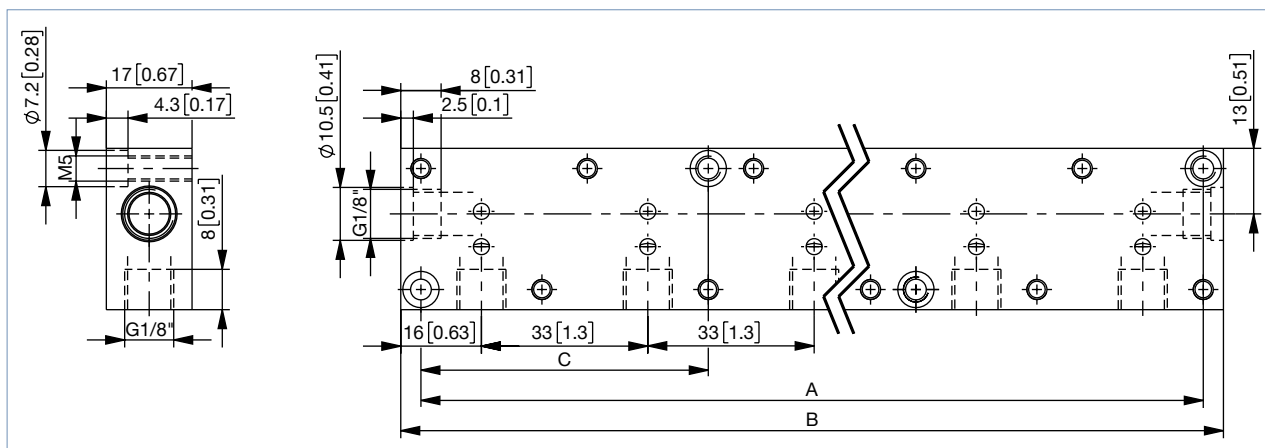

Accessory part	Quantity of valve places	Hole spacing A		Total length B		Hole spacing C		Article no.
		[mm]	[inch]	[mm]	[inch]	[mm]	[inch]	
Multiple manifold (in aluminium)	2	57	2.24	65	2.56	-	-	005023
	3	90	3.54	98	3.86	-	-	005286
	4	123	4.84	131	5.16	-	-	005287
	5	156	6.14	164	6.46	57	2.24	005035
	6	189	7.44	197	7.76	57	2.24	005038
	8	255	10.04	263	10.35	90	3.54	005386
	10	321	12.64	329	12.95	90	3.54	005764
Single manifold (in aluminium)								005020
Connector nipple with O-ring to connect from manifold								005040
Covering plate with screws and O-ring for locking unoccupied valve positions								005630

Manifolds for block mounting**Note:**

- Unused, open valve ports must be closed off with covering plates (see accessories).
- Manifold should be fixed on to a rail.
- For detailed information on dimensions “6.3. Multiple manifold” on page 7.

With manifold mounting, please comply with the permissible duty cycle (5 W models with 100 % continuous rating or standard 8 W model with 60 % duty cycle). The pressure port for the manifold is designated with P (R), and the outlet port with A (B). Only connect together ports with the same designation.

2/2-way valves of Type 6013 can be operated together on a manifold with 3/2-way valves of Type 6014, circuit function C (not D or T!) if the operating pressures matches according to the rating plates. The manifolds can also be expanded if the valve functions are taken into consideration. Connector nipples with O-rings are used to connect the P (R) ports.

7. Performance specifications**7.1. Power consumption****Circuit function A**

Orifice [mm]	Port connection	C _v value water [gal/min]	Weight [g]	Power consumption ^{1.)} [W]	Electr. power		Coil size	Switching times	
					Inrush (AC)	Hold (AC)		Opening [ms]	Closing [ms]
2.0	NPT 1/8	0.14	325	8 W AC or 8 W DC (9)	24 VA	17 VA	5 (32 mm)	20	30
2.0	NPT 1/4	0.14	465	8 W AC or 8 W DC (9)	24 VA	17 VA	5 (32 mm)	20	30
2.0	Flange	0.14	290	8 W AC or 8 W DC (9)	24 VA	17 VA	5 (32 mm)	20	30
2.5	NPT 1/8	0.18	325	8 W AC or 8 W DC (9)	24 VA	17 VA	5 (32 mm)	20	30
2.5	NPT 1/4	0.18	465	8 W AC or 8 W DC (9)	24 VA	17 VA	5 (32 mm)	20	30
3.0	NPT 1/8	0.27	325	8 W AC or 8 W DC (9)	24 VA	17 VA	5 (32 mm)	20	30
3.0	NPT 1/4	0.27	465	8 W AC or 8 W DC (9)	24 VA	17 VA	5 (32 mm)	20	30
3.0	NPT 3/8	0.27	550	10 W AC or 10 W DC (11)	30 VA	22 VA	6 (40 mm)	20	30
4.0	NPT 1/4	0.35	465	8 W AC or 8 W DC (9)	24 VA	17 VA	5 (32 mm)	20	30
4.0	NPT 3/8	0.35	550	10 W AC or 10 W DC (11)	30 VA	22 VA	6 (40 mm)	20	30
6.0	NPT 1/4	0.64	465	8 W AC or 8 W DC (9)	24 VA	17 VA	5 (32 mm)	20	30
6.0	NPT 3/8	0.64	550	10 W AC or 10 W DC (11)	30 VA	22 VA	6 (40 mm)	20	30

1.) Values in brackets correspond to a coil temperature of 20 °C.

Circuit function B

Orifice [mm]	Port connection	C _v value water [gal/min]	Weight [g]	Power consumption ^{1.)} [W]	Electr. power		Coil size	Switching times	
					Inrush (AC)	Hold (AC)		Opening [ms]	Closing [ms]
2.00	NPT 1/8	0.14	325	7 W AC or 8 W DC (9)	24 VA	17 VA	5 (32 mm)	20	30
2.00	NPT 1/4	0.14	465	7 W AC or 8 W DC (9)	24 VA	17 VA	5 (32 mm)	20	30
2.00	Flange	0.14	290	7 W AC or 8 W DC (9)	24 VA	17 VA	5 (32 mm)	20	30
3.00	NPT 1/8	0.27	325	7 W AC or 8 W DC (9)	24 VA	17 VA	5 (32 mm)	20	30
3.00	NPT 1/4	0.27	465	7 W AC or 8 W DC (9)	24 VA	17 VA	5 (32 mm)	20	30
3.00	Flange	0.27	290	7 W AC or 8 W DC (9)	24 VA	17 VA	5 (32 mm)	20	30
4.00	NPT 1/4	0.35	465	7 W AC or 8 W DC (9)	24 VA	17 VA	5 (32 mm)	20	30
6.00	NPT 1/4	0.64	465	7 W AC or 8 W DC (9)	24 VA	17 VA	5 (32 mm)	20	30

1.) Values in brackets correspond to a coil temperature of 20 °C.

8. Product installation

8.1. Installation notes

Control for impulse version with polarity reversal control

Note:

- Please use only the cable plug without electrical circuitry for the impulse version!
- Pulse duration at least 50 ms

Polarity (is marked on the coil with a label)	Features	Terminal connections
- switch ON +	valve open	(+) on terminal 2 and (-) on terminal 1 (see below)
+ switch OFF -	valve closed	(+) on terminal 1 and (-) on terminal 2 (see below)

Polarity is marked on the coil with a label:
- switch ON +
+ switch OFF -

1
Protective conductor port
2

9. Ordering information

9.1. Bürkert eShop – Easy ordering and quick delivery

Bürkert eShop – Easy ordering and quick delivery

You want to find your desired Bürkert product or spare part quickly and order directly? Our online shop is available for you 24/7. Sign up and enjoy all the benefits.

[Order online now](#)

9.2. Bürkert product filter

Bürkert product filter – Get quickly to the right product

You want to select products comfortably based on your technical requirements? Use the Bürkert product filter and find suitable articles for your application quickly and easily.

[Try out our product filter](#)

DTS 1000572169 EN Version: D Status: RL (released | freigegeben | valide) printed: 28.07.2023

9.3. Ordering chart

UL Recognized

Note:

Please note that the cable plug **Type 2518** ▶ is included. UL Listed and other versions are available on request.

For details see “**Cable plug Type 2518, form A according to DIN EN 175301 - 803**” on page 16.

Circuit function	Port connection	Orifice	C _v value water ^{1.)}	Voltage/ Frequency	Coil power	Pressure range ^{2.)} (MAWP ^{3.)})	Article no. Brass body FKM Seal	Article no. Stainless steel body FKM Seal
		[mm]	[gal/min]	[V/Hz]	[W]	[psi]		
With FKM seal, brass or stainless steel body (class B)								
Circuit function A (CF A) 2/2-way solenoid valve Direct-acting Normally closed 	NPT 1/8	2.0	0.14	024/DC	8	0...174	X	X
				024/60		0...363	X	X
				120/60		0...363	X	X
				240/60		0...363	X	X
	NPT 1/4	0.14	024/DC	8	0...174	X	X	
			024/60		0...363	X	X	
			120/60		0...363	X	X	
			240/60		0...363	X	X	
	Flange (SFB)	0.14	024/DC	8	0...174	X	–	
			024/60		0...363	X	–	
			120/60		0...363	X	–	
			240/60		0...363	X	–	
	NPT 1/8	2.5	0.18	8	024/DC	0...145	X	–
					024/60	0...232	X	–
					120/60	0...232	X	–
					240/60	0...232	X	–
	NPT 1/8	3.0	0.27	8	024/DC	0...87	X	X
					024/60	0...145	X	X
					120/60	0...145	X	X
					240/60	0...145	X	X
	NPT 1/4	0.27	8	024/DC	0...87	X	X	
				024/60	0...145	X	X	
				120/60	0...145	X	X	
				240/60	0...145	X	X	
	NPT 3/8	0.27	10	024/DC	0...116	X	–	
				024/60	0...203	X	–	
				120/60	0...203	X	–	
				240/60	0...203	X	–	
	NPT 1/4	4.0	0.35	8	024/DC	0...22	X	X
					024/60	0...58	X	X
					120/60	0...58	X	X
					120/60	0...58	X	X
	NPT 3/8	0.35	10	024/DC	0...36	X	–	
				024/60	0...87	X	–	
				120/60	0...87	X	–	
				240/60	0...87	X	–	
	NPT 1/4	6.0	0.64	8	024/DC	0...7	X	X
					024/60	0...22	X	X
					120/60	0...22	X	X
					240/60	0...22	X	X
	NPT 3/8	0.64	10	024/DC	0...11	X	–	
				024/60	0...36	X	–	
				120/60	0...36	X	–	
				240/60	0...36	X	–	

X: on request

1.) Measurement at 14 psi²⁾ and +68 °F at the valve inlet and free outlet

2.) Pressure data: Overpressure to atmospheric pressure

3.) Maximum allowable working pressure

UL Listed

Note:

Please note that the cable plug **Type 2518** ▶ is included. UL Recognized and other versions are available on request. For details see **"Cable plug Type 2518, form A according to DIN EN 175301 - 803"** on page 16.

Circuit function	Port connection	Orifice	C _v value water ^{1.)}	Voltage/Frequency	Coil power	Pressure range ^{2.)} (MAWP ^{3.)}	Article no. Brass body FKM Seal	Article no. Stainless steel body FKM Seal				
		[mm]	[gal/min]	[V/Hz]	[W]	[psi]						
With FKM seal, brass or stainless steel body (class B)												
Circuit function A (CF A) 2/2-way solenoid valve Direct-acting Normally closed 	NPT 1/8	2.0	0.14	024/DC	8	0...174	332772 ☞	332768 ☞				
				024/60		0...363	X	X				
				120/60		0...363	341755 ☞	332753 ☞				
				240/60		0...363	X	X				
				NPT 1/4		0.14	024/DC	8	0...174	332763 ☞	20013745 ☞	
							024/60		0...363	X	X	
							120/60		0...363	332754 ☞	X	
							240/60		0...363	X	X	
				Flange (SFB)		0.14	0.14	8	024/DC	0...174	X	-
									024/60	0...363	X	-
									120/60	0...363	X	-
									240/60	0...363	X	-
	NPT 1/8	2.5	0.18	8	024/DC	0...145	332761 ☞	-				
					024/60	0...232	X	-				
					120/60	0...232	341756 ☞	-				
					240/60	0...232	X	-				
	NPT 1/8	3.0	0.27	8	024/DC	0...87	332775 ☞	341751 ☞				
					024/60	0...145	332765 ☞	X				
					120/60	0...145	332762 ☞	332755 ☞				
					240/60	0...145	X	X				
					NPT 1/4	0.27	8	024/DC	0...87	332773 ☞	X	
								024/60	0...145	332774 ☞	X	
								120/60	0...145	332758 ☞	X	
								240/60	0...145	X	X	
	NPT 3/8	0.27	0.27	10	024/DC	0...116	X	-				
					024/60	0...203	X	-				
					120/60	0...203	X	-				
					240/60	0...203	X	-				
	NPT 1/4	4.0	0.35	8	024/DC	0...22	332750 ☞	341753 ☞				
					024/60	0...58	X	X				
					120/60	0...58	332757 ☞	341757 ☞				
					240/60	0...58	X	X				
					NPT 3/8	0.35	10	024/DC	0...36	X	-	
								024/60	0...87	X	-	
								120/60	0...87	X	-	
								240/60	0...87	X	-	
	NPT 1/4	6.0	0.64	8	024/DC	0...7	X	X				
					024/60	0...22	X	X				
					120/60	0...22	X	X				
					240/60	0...22	X	X				
					NPT 3/8	0.64	10	024/DC	0...11	X	-	
								024/60	0...36	X	-	
								120/60	0...36	X	-	
								240/60	0...36	X	-	

X: on request

1.) Measurement at 14 psi^{2.)} and +68 °F at the valve inlet and free outlet

2.) Pressure data: Overpressure to atmospheric pressure

3.) Maximum allowable working pressure

DTS 1000572169 EN Version: D Status: RL (released | freigegeben | valide) printed: 28.07.2023

UL Recognized Normally Open

Note:

Please note that the cable plug **Type 2509** ▶ is included. UL Listed and other versions are available on request. For details see **“Cable plug Type 2509, form A according to DIN EN 175301 - 803” on page 15.**

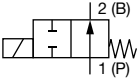
Circuit function	Port connection	Orifice	C _v value water ^{1.)}	Voltage/ Frequency	Coil power	Pressure range ^{2.)} (MAWP ^{3.)})	Article no.	
		[mm]	[gal/min]	[V/Hz]	[W]	[psi]	Brass body	Stainless steel body
With FKM seal and brass body (class H)								
Circuit function B (CF B) 2/2-way solenoid valve Direct-acting Normally open 	NPT 1/8	2.0	0.14	24/DC 120/60	8 7	0...232	X	X
	NPT 1/8	3.0	0.27	24/DC	8	0...116	X	X
				120/60	7		X	X
	NPT 1/4	4.0	0.35	24/DC	8	0...58	X	X
				120/60	7		X	X
	NPT 1/4	6.0	0.64	24/DC	8	0...29	X	X
				120/60	7		X	X

X: on request

1.) Measurement at 14 psi²⁾ and +68 °F at the valve inlet and free outlet

2.) Pressure data: Overpressure to atmospheric pressure

3.) Maximum allowable working pressure

UL Recognized low temperature version (-40 °F)

Note:

Please note that the cable plug **Type 2509** ▶ is included. UL Listed and other versions are available on request. For details see **“Cable plug Type 2509, form A according to DIN EN 175301 - 803” on page 15.**

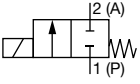
Circuit function	Port connection	Orifice	C _v value water ^{1.)}	Voltage/ Frequency	Coil power	Pressure range ^{2.)} (MAWP ^{3.)})	Article no.	
		[mm]	[gal/min]	[V/Hz]	[W]	[psi]	Brass body	Stainless steel body
With FKM seal and brass body (class B)								
Circuit function A (CF A) 2/2-way solenoid valve Direct-acting Normally closed 	NPT 1/8	2.0	0.12	24/DC 120/60	8 8	0...174 0...363	X	X
	NPT 1/8	2.5	0.16	24/DC	8	0...145	X	X
				120/60	8		0...232	X
	NPT 1/4	3.0	0.23	24/DC	8	0...87	X	X
				120/60	8		0...145	X
	NPT 1/4	4.0	0.30	24/DC	8	0...22	X	X
				120/60	8		0...58	X

X: on request

1.) Measurement at 14 psi²⁾ and +68 °F at the valve inlet and free outlet

2.) Pressure data: Overpressure to atmospheric pressure

3.) Maximum allowable working pressure

9.4. Ordering chart coil to be UL Listed for hazardous locations, Class I, Division 2

Cable versions

Note:

- The maximum medium temperature may never exceed the permissible temperature class (T4 275 °F, T5 212 °F, T6 185 °F) minus 5K.
- With 3 m/9'10" cable as standard. Other lengths or version with junction box on request.

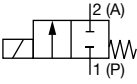
Circuit function	Port connection	Orifice	C _v value water ^{1.)}	Voltage/ Frequency	Coil power	Pressure range ^{2.)} (MAWP ^{3.)})	Article no.		
		[mm]	[gal/min]	[V/Hz]	[W]	[psi]	Brass body	Stainless steel body	
Ex m T4 approved, with FKM seal and molded cable (3 m/9'10"), single mounting only									
Circuit function A (CF A) 2/2-way solenoid valve Direct-acting Normally closed 	Flange (SFB)	2.0	0.13	24/UC	7	0...87	X	X	
				120/UC			X	X	
	NPT 1/8			0.14	24/UC	9	0...145	X	X
					120/UC			X	X
	NPT 1/4			0.14	24/UC	9	0...145	X	X
					120/UC			X	X
	NPT 1/8	2.5		0.18	24/UC	9	0...116	X	X
					120/UC			X	X
	NPT 1/8	3.0		0.27	24/UC	9	0...73	X	X
					120/UC			X	X
	NPT 1/4			0.27	24/UC	9	0...73	X	X
					120/UC			X	X
	NPT 1/4	4.0		0.35	24/UC	9	0...17	X	X
					120/UC			X	X
NPT 1/4	6.0		0.64	24/UC	9	0...6	X	X	
				120/UC			X	X	

X: on request

1.) Measurement at 14 psi²⁾ and +68 °F at the valve inlet and free outlet

2.) Pressure data: Overpressure to atmospheric pressure

3.) Maximum allowable working pressure

9.5. Ordering chart coil to be cFMus for hazardous locations, Class I, Division 1

Conduit versions

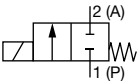
Circuit function	Port connection	Orifice	C _v value water ^{1.)}	Voltage/Frequency	Coil power	Pressure range ^{2.)} (MAWP ^{3.)}	Article no.	
		[mm]	[gal/min]	[V/Hz]	[W]	[psi]	Brass body	Stainless steel body
cFMus approved coil, with FKM seal and molded cable (19.5 inch), single mounting only								
Circuit function A (CF A) 2/2-way solenoid valve Direct-acting Normally closed 	Flange (SFB)	2.0	0.13	24/UC	7	0...87	X	X
							120/UC	X
	NPT 1/8	2.0	0.14	24/UC	9	0...145	X	X
							120/UC	X
	NPT 1/4	2.0	0.14	24/UC	9	0...145	X	X
							120/UC	X
	NPT 1/8	2.5	0.18	24/UC	9	0...116	X	X
							120/UC	X
	NPT 1/8	3.0	0.27	24/UC	9	0...73	X	X
							120/UC	X
	NPT 1/4	3.0	0.27	24/UC	9	0...73	X	X
							120/UC	X
	NPT 1/4	4.0	0.35	24/UC	9	0...17	X	X
							120/UC	X
NPT 1/4	6.0	0.64	24/UC	9	0...6	X	X	
						120/UC	X	X

X: on request

- 1.) Measurement at 14 psi^{2.)} and +68 °F at the valve inlet and free outlet
- 2.) Pressure data: Overpressure to atmospheric pressure
- 3.) Maximum allowable working pressure

DTS 1000572169 EN Version: D Status: RL (released | freigegeben | valide) printed: 28.07.2023

9.6. Ordering chart accessories

Single manifold

Note:

Detailed ordering information can be found in chapter “6.2. Single manifold” on page 7.

Multiple manifold

Note:

Detailed ordering information can be found in chapter “6.3. Multiple manifold” on page 7.

Cable plug Type 2509, form A according to DIN EN 175301 - 803

Note:

- The cable plug meets the requirements for UL hazloc Div. 2
- Without circuitry (Standard)
- For more information on the cable plug, see data sheet **Type 2509** ▶.

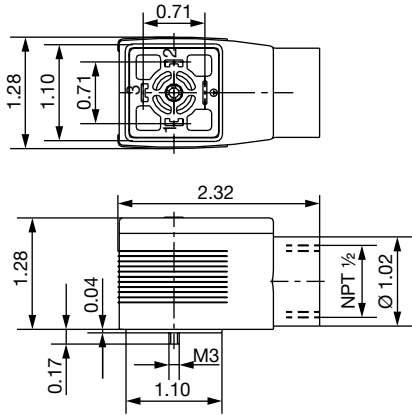
Cable plug	Dimensions	Version	Voltage	Article no.
		Without circuitry	0...250 V AC/DC	137943 𐀀





DTS 1000572169 EN Version: D Status: RL (released | freigegeben | validé) printed: 28.07.2023

Cable plug Type 2518, form A according to DIN EN 175301 - 803

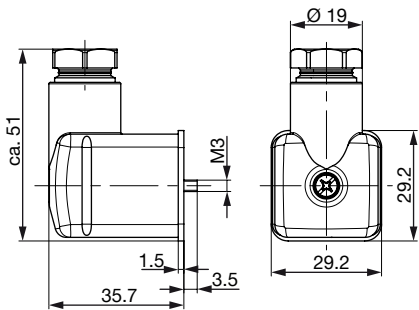
Note:

For further versions see data sheet **Type 2518** ▶

Cable plug	Dimensions	Version	Voltage	Article no.
		Without circuitry (AC/DC)	0...250 V AC/DC	314802
		With LED (AC/DC)	12...24 V AC/DC	314812
		With LED and varistor (AC/DC)	12...24 V AC/DC	314820
		With rectifier, LED and varistor	12...24 V AC/DC	314816
		Without circuitry (AC/DC) with silicone seal for higher ambient temperature, e.g. steam version (NA07)	0...250 V AC/DC	361687

Further versions on request	
 <p>Approval UL / UR / CSA UL Hazloc Div 2 FM Hazloc Div 1 European gas approval Class A, Group 2 Analytical versions</p>	 <p>Pressure Variants with increased coil power for higher medium pressure</p>
 <p>Material Seal material FKM, EPDM, NBR, PTFE</p>	 <p>Process connection Threaded port G, Rc, manifold</p>
	 <p>Voltage Further voltages</p>

Bürkert – Close to You

For up-to-date addresses
please visit us at
www.burkert.com

DTS 1000572169 EN Version: D Status: RL (released | freigegeben | validé) printed: 28.07.2023

Austria
Belgium
Czech Republic
Denmark
Finland
France
Germany
Italy
Netherlands

Norway
Poland
Spain
Sweden
Switzerland
Turkey
United Kingdom

