



FREE FLOAT[®] STEAM TRAP

FOR RUBBER VULCANIZERS

MODEL J3S-X S Series CAST STAINLESS STEEL

FREE FLOAT STEAM TRAP WITH THREE-POINT SEATING AND THERMOSTATIC AIR VENTING

Features

A reliable and durable stainless steel steam trap with tight shut-off designed for use on rubber vulcanizers.

1. Self-modulating free float provides continuous, smooth, low velocity condensate discharge as process loads vary.
2. Precision-ground float, constant water seal and three-point seating design ensure a steam tight seal, even under no-load conditions.
3. Special thermostatic capsule (X-element) with "fail open" feature vents air automatically until close-to-steam temperature.
4. Cover plug can be removed to allow an LR3 lock release valve to be installed for combatting steam locking.
5. Drain plug allows a manual or automatic valve to be installed for condensate blowdown.
6. S1 model eliminates wire mesh from the internal screen to help avoid clogging with rust and scale.

Pressure Equipment Directive (PED)

Classification according to PED 2014/68/EU, fluid group 2

Size	Category	CE marking
DN 15 to DN 25	—*	Art. 4, Sec. 3 (sound engineering practice), CE marking not allowed

* Manufactured in accordance with sound engineering practice

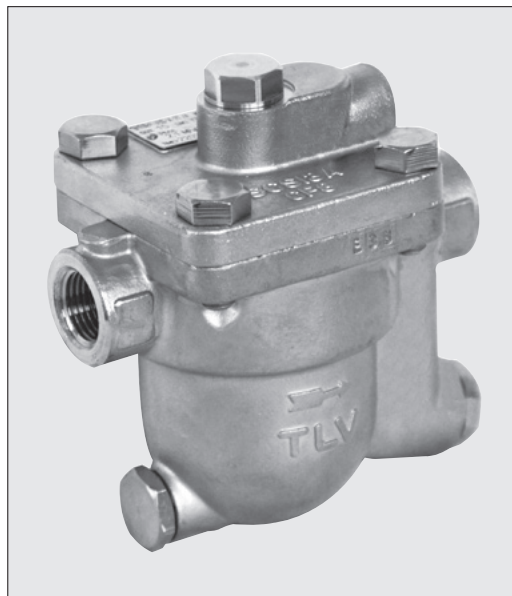

Specifications

Model	J3S-X S1		J3S-X S2	
	Screwed	Flanged	Screwed	Flanged
Connection				
Size	½", ¾", 1"	DN 15, 20, 25	½", ¾", 1"	DN 15, 20, 25
Orifice No.				10, 14
Maximum Operating Pressure (barg) PMO				10, 14
Maximum Differential Pressure (bar) ΔPMX				10, 14
Maximum Operating Temperature (°C) TMO				220
Subcooling of X-element Fill (°C)				up to 11
Type of X-element				C11
Internal Screen	φ1.2 mm punched hole with 1.8 mm pitch (equivalent to 16 mesh)		φ1.2 mm punched hole with 1.8 mm pitch + wire mesh (60 mesh)	

PRESSURE SHELL DESIGN CONDITIONS (NOT OPERATING CONDITIONS): Maximum Allowable Pressure (barg) PMA: 21 1 bar = 0.1 MPa
Maximum Allowable Temperature (°C) TMA: 220



To avoid abnormal operation, accidents or serious injury, DO NOT use this product outside of the specification range. Local regulations may restrict the use of this product to below the conditions quoted.

No.	Description	Material	DIN*	ASTM/AISI*
①	Body	Cast Stainl. Steel A351 Gr.CF8	1.4312	—
②	Cover	Cast Stainl. Steel A351 Gr.CF8	1.4312	—
③	Float	Stainless Steel SUS316L	1.4404	AISI316L
④	Orifice Plug	Cast Stainl. Steel A351 Gr.CF8	1.4312	—
⑤	Orifice Plug Gasket	Stainless Steel SUS316L	1.4404	AISI316L
⑥	Orifice	—	—	—
⑦	Orifice Gasket	Stainless Steel SUS316L	1.4404	AISI316L
⑧	Screen inside/outside**	Stainless Steel SUS430/304	1.4016/1.4301	AISI430/304
⑨	Cover Gasket	Fluorine Resin PTFE	PTFE	PTFE
⑩	Nameplate	Stainless Steel SUS304	1.4301	AISI304
⑪	Float Cover	Stainless Steel SUS304	1.4301	AISI304
⑫	X-element Guide	Stainless Steel SUS304	1.4301	AISI304
⑬	X-element	Stainless Steel	—	—
⑭	Spring Clip	Stainless Steel SUS304	1.4301	AISI304
⑮	Air Vent Valve Seat	Stainless Steel SUS420F	1.4028	AISI420F
⑯	Connector	Stainless Steel SUS416	1.4005	AISI416
⑰	Cover Bolt	Stainless Steel SUS304	1.4301	AISI304
⑱	Flange***	Cast Stainl. Steel A351 Gr.CF8	1.4312	—
⑲	Drain Plug Gasket	Stainless Steel SUS316L	1.4404	AISI316L
⑳	Drain Plug	Stainless Steel SUS303	1.4305	AISI303
㉑	Cover Plug	Stainless Steel SUS303	1.4305	AISI303
㉒	Cover Plug Gasket	Fluorine Resin PTFE	PTFE	PTFE

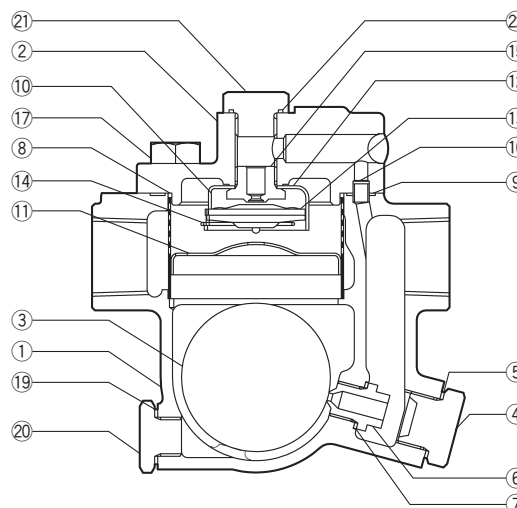

Copyright © TLV

* Equivalent materials ** Outside screen (wire mesh) on S2 model only
*** Shown on reverse

Dimensions

● J3S-X S Series Screwed

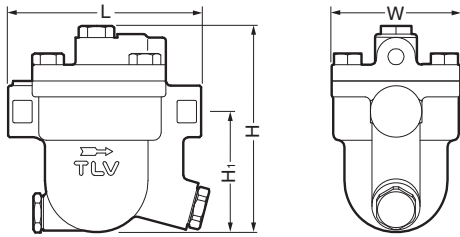

J3S-X S Series Screwed* (mm)

Size	L	H	H ₁	W	Weight (kg)
1/2"	120	130	75	80	2.5
3/4"			72.5		2.6
1"		137	75		2.8

* BSPT; other standards available

● J3S-X S Series Flanged

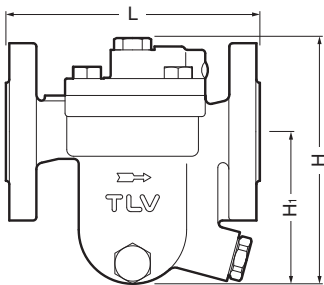

DIN type is shown.
ASME type has welded on flanges.

J3S-X S Series Flanged (mm)

DN	L			H		H ₁		Weight (kg)*
	DIN 2501	ASME Class		DIN	ASME	DIN	ASME	
	PN25/40	150RF	300RF					
15	150	195	195	132	130	84	75	3.4
20		215	215	140		90		3.6
25	160	235	235	147		92		4.6

* Weight is for PN25/40

Discharge Capacity

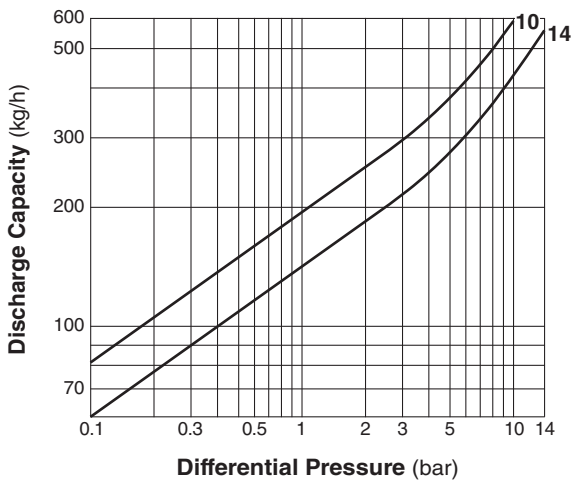

- Line numbers within the graph are orifice numbers.
- Differential pressure is the difference between the inlet and outlet pressure of the trap.
- Capacities are based on continuous discharge of condensate 6 °C below saturated steam temperature.
- Recommended safety factor: at least 1.5.



DO NOT use this product under conditions that exceed maximum differential pressure, as condensate backup will occur!

Usage

Application Example

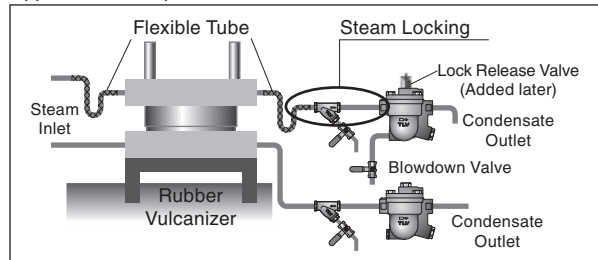

For explanation purposes only, not intended as installation designs.

- In steam using rubber vulcanizers the heat plate moves up and down making it easy for steam locking to occur. This can result in condensate backup, which causes temperature drops. The S series has a plug in the cover that can be removed to allow an LR3 lock release valve to be installed for combating this problem. By opening the valve a tiny amount to release "locked" steam, the proper temperature can be ensured.

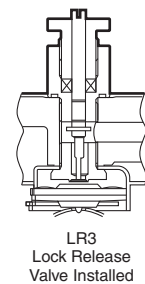

- A drain plug at the bottom of the body is equipped as standard. By removing the plug and installing a manual or automatic blowdown valve, condensate blowdown can be carried out when there is a temperature drop.

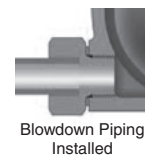

Note: Since the thread standard is G(PF1/4), a thread conversion fitting is needed for piping.

Manufacturer

TLV CO., LTD.

Kakogawa, Japan

is approved by LRQA Ltd. to ISO 9001/14001

ISO 9001
ISO 14001

